

PALM-SIZED TEMPERATURE/HUMIDITY METER HN-CH SERIES



High performance temperature/humidity meter with data logging function !!!

The HN-CH series is reliable and accurate palm-sized temperature/humidity meter with the measuring humidity range of 0 to 100%RH by using a new developed humidity sensor.

It also provides the data logging function capable to store each 8000 readings of temperature and humidity into memory.

■ FEATURES

- Measurement of relative humidity 0 to 100%RH by capacitance type humidity sensor
- High accurate measurement in low humidity area less than 20%
- Improved repeatability and reliability by a new developed humidity sensor
- Logging function of up to each 8000 readings of temperature and humidity
- Easy maintenance by complete interchangeable sensors
- Three types of sensors, sensor built-in type, probe type and separated type, are prepared for various applications.
- Data logging software package
A software package for analyzing data measured by HN-CH is available shortly. Two modes, real-time monitoring mode of measured data and analyzing mode of data stored into memory, are prepared with a trend screen and a data screen. It also has a data exporting function to worksheet applications. The RS-485 communications type can be used for wide applications as a multiple temperature/humidity measuring system by using an optional AC adapter.



■ MODELS

- HN-CH□□
- Type of sensor
 - N: Sensor built-in type
 - P: Probe type (with 1.5m cable)
 - T: Separated type (with 1.5m cable)
 - Communications interface
 - R: RS-232C
 - S: RS-485

■ APPLICATIONS

- Environmental testing equipments, chambers, clean benches
- Food storage, grain storage, green houses
- Art galleries, museums
- Food transport trucks

■ GENERAL SPECIFICATIONS

Relative humidity	Sensor	High-polymer capacitance type
	Measuring range	0 to 100%RH
	Accuracy rating	±2%RH (at 0 to 90%RH and 25°C) ±3%RH (at 90 to 95%RH and 25°C)
	Temperature coefficient	±0.1%RH/°C (5 to 80°C)
	Response time	Within 15 seconds (90% response, 25°C constant, under 0.1m/s ventilation)
Temperature	Sensor	Semiconductor type temperature sensor
	Measuring range	-10 to 50°C -40 to 80°C (Probe type HN-CHP, Separated type HN-CHT)
	Accuracy rating	±0.5°C (0 to 50°C) ±1°C (except above)
Sensor interchangeability		Interchangeable by plug-in For probe type and separated type, interchangeable including cable
Power supply		2 AA batteries or 100VAC (By AC adapter: Sold separately)
Display	Current data	Month, day, hour, minute Temperature reading (°C or °F) Relative humidity or dew-point temperature reading (°C or °F)
	Replaying data	Parameters Logged data at each year, month, day, hour or minute Maximum temperature/humidity, minimum temperature/humidity,
	Parameters	Clock: Year, month, day, hour, minute, Temperature: °C/°F Relative humidity, dew-point temperature (°C or °F) Logging type: Manual or interval Logging start time: Year, month, day, hour, minute or direct Logging end time: Year, month, day, hour, minute or direct Logging repetition: No repetition, every day, every week Measuring interval: Continuous, 1 to 60 minutes High alarm, low alarm, reference temperature for totalizing, totalizing direction, auto power-off, key lock
	Display contents	Clock constantly, measured value by key-touch at OFF
Number of logging data		Temperature/humidity: Up to 8000 data each, total 16000 data (EEPROM)
Communications function		RS-232C or RS-485

■ DIMENSIONS

● Meter

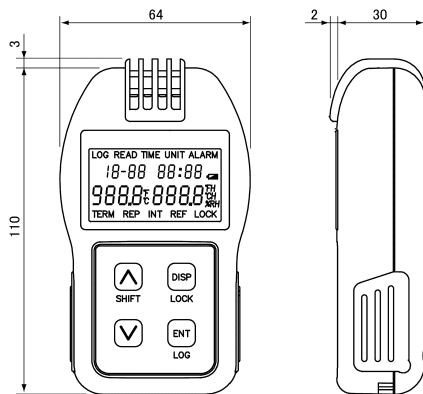

● Probe type sensor ● Separate type sensor

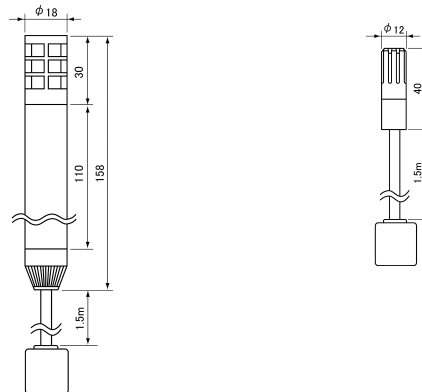

Specifications subject to change without notice. Printed in Japan (I) 2002.1

CHINO CORPORATION

32-8, KUMANO-CHO, ITABASHI-KU, TOKYO 173-8632
 PHONE: +81-3-3956-2171
 FAX: +81-3-3956-0915
 E-mail: inter@chino.co.jp
 Website: <http://www.chino.co.jp>